

Hydrophilic Construction Joint Waterstop**Description**

A flexible hydrophilic natural rubber & bentonite waterstop for construction joints and seal precast elements that expands on contact with water. The **Bentonite Cast Seal** consist of tightly packed charged microscopic platelets, between and within these platelets there is separation of charges positive and negative. Water molecules are attracted to the unique structure of positive and negative charges and wedge themselves between the platelets causing them to separate & swell. The hydrated bentonite forms a seal preventing further migration of water. As hydrostatic pressure is increased the platelets compact forming a tighter seal.

Uses

Bentonite Cast Seal is used to stop water infiltration through both vertical and horizontal non moving construction joints, irregular surfaces and around penetrations through concrete. It is not intended as an expansion joint sealant. It is designed to replace conventional waterstops in construction joints. The sodium bentonite in **Bentonite Cast Seal** is the key to its success. Bentonite swells and is released (free expansion) when in contact with water blocking pores, capillaries, minor cracks & other paths for water forming a permanent impermeable barrier.

Typical Areas of Application Include

Below and above grade structure such as water tanks, waste water treatment plants, tunnels, basements, lift shafts, underground stations, subway systems, manholes, swimming pools, canals etc.

ADVANTAGES

- Light weight flexible coils easy to install.
- Eliminates seam welding & split forming associated with PVC/rubber waterbars.
- Butt end joining, continuous waterstop.
- Withstands hydrostatic water head up to 70 metres.
- Form a positive seal, sealing cracks & small voids.
- May use in portable water tanks. Non toxic.
- Can apply to irregular concrete surfaces. No need to level.
- Compressible and malleable allowing for good contact in precast applications.
- Unaffected by repeated wetting & drying cycles.
- Does not deteriorate lasts life of structure.
- Permanently active system.

Packing Size:**Bentonite Cast Seal 25**
Bentonite Cast Seal 20**25mm x 19mm x 5 meter roll**
20mm x 15mm x 5 meter roll**Adhesive****Epo Bond Adhesive****1 Litre tin [Coverage: 20-30 M/Litre]**

Typical Properties

Hydrostatic Head Resistance	> 70 m	
Specific Gravity	>1.40	ASTM D-71
Wet/Dry Cycling	No effect	
Service Temperatures	-40°C to 80°C	
Elongation	> 300%	
Typical Expansion	> 177 until 300%	
Volatile Matter	1% max.	ASTM D-6
Application Temp. Range	-10°F to 125°F	(-23°C to 52°C)
Service Temp Range	-30°F to 180°F	(-34°C to 82°C)

Method of Application

Surfaces should be clean, free of all curing compounds, mould oils and dry with all dirt, aggregate, rust, debris or standing water removed.

Apply by brush **Epo Bond Adhesive**, adhesive along the concrete by the width of **Bentonite Cast Seal**. Whilst still tacky (within 10-15 minutes) apply the **Bentonite Cast Seal**. Remove the release paper and press the **Bentonite Cast Seal** firmly to the surface for several seconds. At the highest coil end on vertical sections pay particular attention. If the adhesive has dried out reapply to the surface. Mechanical fasteners may be used in conjunction with adhesive. Tightly butt end together to form a continuous waterstop. Do not prehydrate or submerge in water. If severe ground water chemicals or salts exist consult with **LaMaCo System Sdn Bhd**.

**Nailing in place to rough surface****Installing around pipes****Specification**

The waterstop to be used in all construction joints shall be **Bentonite Cast Seal** or equal approved material. The waterstop shall consist of sodium bentonite in natural rubber and expand by at least 300%. It shall be capable of being butt ended, shall not be overlapped nor create a packing effect in the concrete, it shall be pliable so that it follows the contours of the concrete and may be installed to all penetrations. The material will form a positive seal, and a continuous waterstop withstanding hydrostatic pressure up to 70 m.

Drawing Details

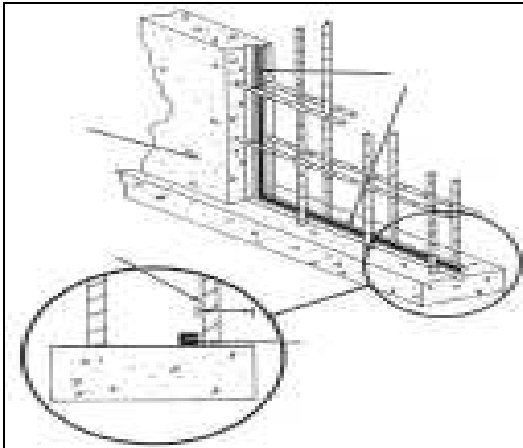

Typical placement of **Bentonite Cast Seal** at concrete construction joints

Penetrations

Multiple pipe: install around each pipe as well as around block out box construction.

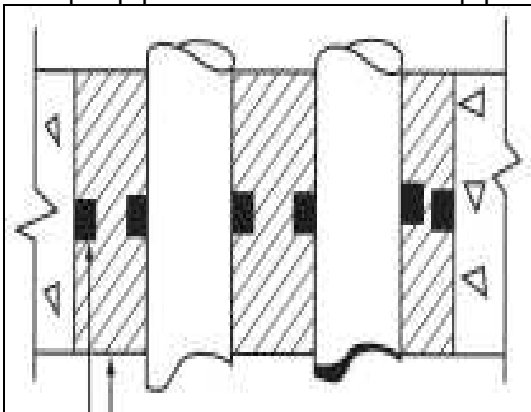

Bentonite Cast Seal

Joining to PVC Waterstop

Install **Bentonite Cast Seal** on the interior side of the PVC water bar place in direct contact and overlap the PVC water bar by at least 7.5 cm.

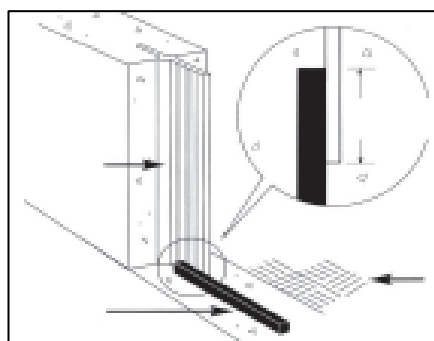

Bentonite Cast Seal



Bentonite Cast Seal
Size: 19mm x 25mm x 5m/roll

Handling Precautions

Mandatory and recommended industrial hygiene procedures should be followed whenever our products are being handled and processed. For additional information please consult the corresponding product safety data sheets and the brochure "Hygienic Precautions for Handling Plastic Products"

The General Term & Conditions

All recommendations for use of our product, whether given by us in writing, verbally, or to be implied from the results of tests carried out by us are based on the current state of our knowledge. Notwithstanding any such recommendations the Buyer shall remain responsible for satisfying himself that the products as supplied by us are suitable for this intended process or purpose. Since we cannot control the application, use or processing of the products, we cannot accept responsibility therefor. The Buyer shall ensure that the intended use of the products will not infringe any third party's intellectual property rights. We warrant that our products are free from defects in accordance with and subject to our general conditions of supply.



LaMaCo System Sdn Bhd

407, Jalan Perusahaan 6, Taman Bandar Baru Mergong,
05150 Alor Setar, Kedah, Malaysia

Tel : +60-4-771 1111

Fax : +60-4-772 4444

Http : www.lamaco.com

Email : info@lamaco.com

IMPORTANT: While the information and data sheet contained in this promotional literature are presented in good faith and believed to be reliable, they do not constitute a part of our terms and conditions of sales unless specifically incorporated in our Order acknowledgement. Nothing herein shall be deemed to constitute a warranty, express or implied, that said information or data sheet are correct or that the products described are merchantable or fit for a particular purpose, or that said information, data sheet or products can be used without infringing patent of third parties.